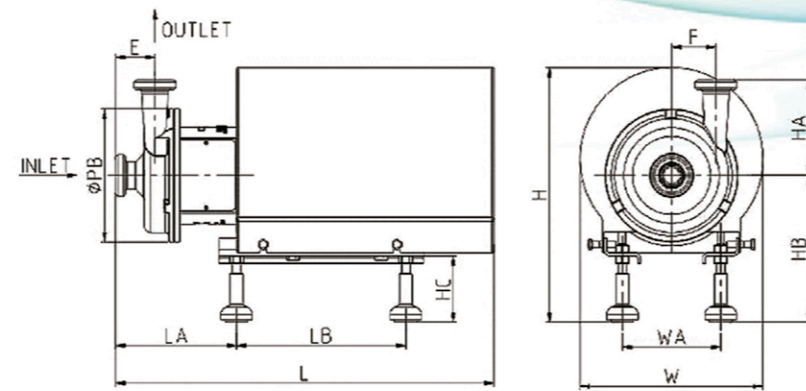

衛生級離心泵性能選型表
 SCP Series performance selection table

型號 Model	功率 Power	流量 Flow rate (m ³)	揚程 Head (M)	進口/出口 Inlet&outlet	理論重量 (KG)
SCP-10	1.1KW	3	22	1.5"/1.5"	30
	1.1KW	5	22		30
	1.5KW	3	22		36
	1.5KW	5	22		36
	1.5KW	8	22		36
	1.5KW	9	22		36
	1.5KW	12	20		36
	1.5KW	15	18		36
	2.2KW	18	16		40
	2.2KW	3	28		39
SCP-15	1.5KW	5	28	2"/1.5"	39
	1.5KW	8	26		39
	2.2KW	10	25		42
	2.2KW	15	22		42
	2.2KW	18	18		42
	2.2KW	20	16		42
	3.0KW	20	16		54
	2.2KW	5	36		47
	3.0KW	10	36		56
	4.0KW	15	35		61
SCP-20-1	4.0KW	20	33	2"/2"	61
	4.0KW	25	30		61
	5.5KW	30	30		83
	5.5KW	38	22		83
	5.5KW	20	40		82
	5.5KW	25	37		82
	5.5KW	30	36		82
	5.5KW	36	32		82
	7.5KW	40	30		86
	7.5KW	45	28		86
SCP-25	4.0KW	5	50	2.5"/1.5"	61
	5.5KW	10	50		82
	5.5KW	15	48		82
	5.5KW	20	45		82
	5.5KW	10	60		83
SCP-30	5.5KW	15	55	2.5"/1.5"	83
	5.5KW	20	50		83
	7.5KW	25	45		87
	7.5KW	30	40		87
	7.5KW	30	40		87

 衛生級離心泵過程示意圖
 SCP Series cnetrifugal pump process

※ 本公司有變更資料之權利，訂購前請先電話確認。

 衛生級離心泵尺寸圖
 SCP Series pump dimension

SCP 系列 Series	泵頭規格 Pump head dimension				外型安裝尺寸 Assembly Dimension							進/出口連接方式 Inlet / outlet connection			
	功率 Power (KW)	進口 Inlet d"/DN	出口 Outlet d"/DN	ΦPB	F	LB	H	HB	HC	W	WA	INCH卡箍連接 Clamp connection			
												E	LA	HA	L
SCP-10	1.1KW	1.5"	1.5"	189	63	240	337	199	94.8	250	125	49	163.7	129	504.7
	1.5-2.2KW	1.5"	1.5"	189	63	240	359	189		260	140	49	163.7	129	526.7
SCP-15	1.5-2.2KW	2"	1.5"	250	95	240	359	189	94.8	260	140	41	163.7	148	526.7
	3KW	2"	1.5"	250	95	300	413	219		320	160	41	143.7	148	568.7
SCP-20-1	2.2KW	2"	2"	250	92	240	362	189	94.8	320	140	38	158.2	163	576.7
	3KW	2"	2"	250	92	300	416	219		340	160	38	165	163	574
SCP-20-2	4KW	2"	2"	250	92	300	421.5	211	94.8	380	190	38	168	163	587
	5.5-7.5KW	2"/2.5"	2"	250	92	330	466	231		340	216	38	160	163	580
SCP-25	4KW	3"	1.5"	328	127.5	300	421.5	211	94.8	380	190	49	189.2	183	668.7
SCP-30	5.5-7.5KW	3"	1.5"	328	127.5	330	466	231		380	216	49	189.2	183	668.7
SCP-35-1	11-15KW	3"	1.5"	363	131	450	551	260	94.8	470	254	65	228.2	222	803.2
	15KW	3"	2"	363	131	450	551	260		470	254	65	228.2	222	803.2
SCP-35-2	18.5KW	3"	2"	363	131	450	551	260	94.8	470	254	65	228.2	222	803.2
	11-15KW	3"	2.5"	315	105	450	551	260		470	254	61.5	237.2	202.5	811.7
SCP-40-1	18.5KW	3"	2.5"	315	105	450	551	260	94.8	470	254	61.5	237.2	202.5	812
	22KW	3"	2.5"	315	105	515	583	281		510	279	61.5	232.2	202.5	907.2
SCP-40-2	30KW	3"	2.5"	315	105	580	655	301	94.8	580	318	61.5	243.2	202.5	953.2

 注意：以上數據圖相關尺寸不作為實物最終依據，本公司保留對於數據更新權限不再另行通知。
 Note: The relevant dimensions of the above data diagrams are not regarded as the final basis of the actual object.
 DONJOY reserves the right to update the data without further notice.

大川泵浦企業股份有限公司 DAH CHUAN PUMP INDUSTRY CO., LTD.
<http://www.cnc-pump.com.tw>

宜蘭總公司(宜蘭廠)

地址:宜蘭縣冬山鄉香中路232巷36號

電話:03-959-1298(代表號) 傳真:03-959-1167

台中分公司:台中市北屯區后庄路252號

TEL:04-2426-2658 FAX: 04-2426-2112

e-mail: cncpump@yahoo.com.tw

※ 本公司有變更資料之權利，訂購前請先電話確認。

SCP 型衛生級離心泵浦

誠信 · 專業 · 創新

Trustworthy · Professional · Creative

ISO 9001:2015、CNS12681

國際認證合格廠商

ISO 14001環境品保認證

SCP系列 / SCP Series

此離心泵材質為不銹鋼製造,並附有不銹鋼電機防護外罩
具衛生和低成本效益的設計,非常適合於乳製品、飲料、食品加工、
製藥和精緻化化工使用

The centrifugal pump is manufactured in stainless steel and with a shrouded motor. Sanitary and cost-efficient design makes it perfect for the dairies, beverages, food-processing, pharmaceutical and fine chemicals industries.

技術規格 Technical specifications

最大流量: 140 m³/h
Max.Flow: 140 m³/h
最高揚程: 70M
Max.Head: 70M
最高溫度: 120 °C / 248 °F (30Min CIP/SIP)
Max.working temperature: 120 degree C/248 degree °F (30Min CIP/SIP)
最高轉速: 3500 RPM
Max.Rev: 3500 RPM

設計特點 Design and feature

電機外罩採不銹鋼冷成型製成,開放式葉輪或密閉式葉輪採不銹鋼熔模鑄造
可調節不銹鋼腳架,ICE或NEMA B35電機 IP55 F級絕緣 50Hz 60Hz
Casing manufactured with cold-formed plate. Open impeller and close impeller manufactured with stainless steel investment casting
Adjustable stainless steel legs, Pump designed according to IEC or NEMA B34 motors, IP 55, F-class insulation, 50HZ,60HZ

材質 Materials

接液處: AISI-316L/304
Parts in contact with pumped media: AISI-316/304
墊圈(標準): EPDM
Gaskets(standard): EPDM(FDA)
機械軸封: SIC/CARBON/EPDM
Mechanical seal(standard): SIC/CARBON/EPDM
內表面處理: Ra≤0.6µm
Inside surface finishing: Ra≤0.8µm
外表面處理: 噴砂處理或拋光處理
Outside surface finishing: Sandblast or Mirror polish

選配項目 Options

機械軸封材質: SIC/SIC, TC/TC
Mechanical seal in: SIC/SIC, TC/TC
墊圈: FPM(VITON), EPDM
Gaskets in: FPM (VITON) and EPDM
機械軸封: 單機械軸封(標準), 沖洗式雙機械軸封
Mechanical seal: Single mechanical seal(standard), Flushed Double mechanical seal(Options)
出入口連接方式: 夾接 螺紋 法蘭
Connections: Clamp, thread, flange
防爆馬達: EG3 / D2G4
Explosion-proof motors: EG3 / D2G4

※ 本公司有變更資料之權利, 訂購前請先電話確認。

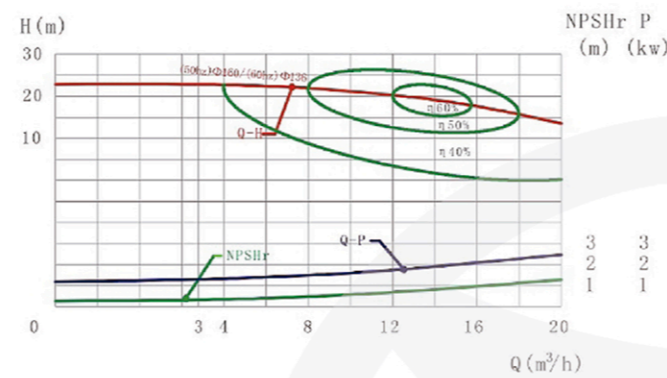
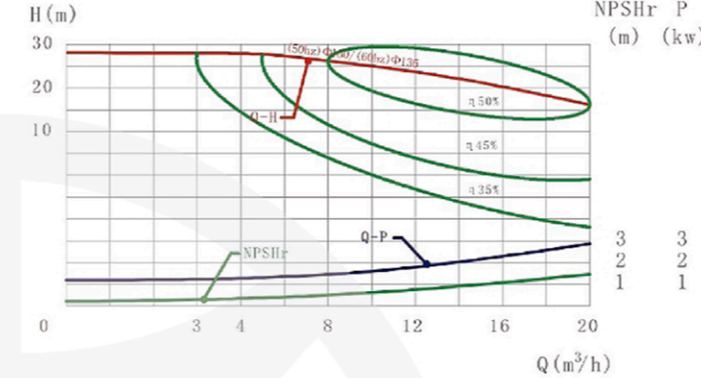
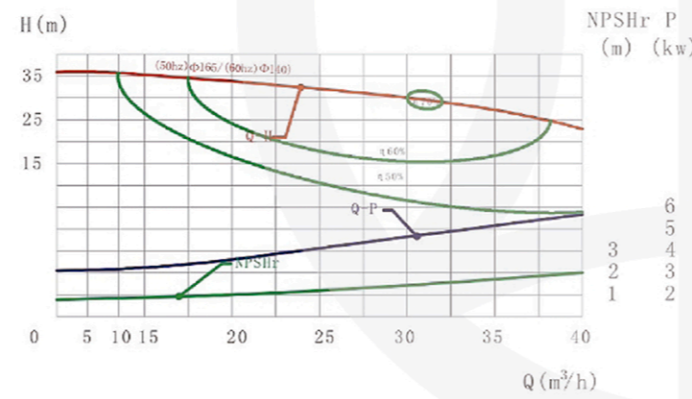
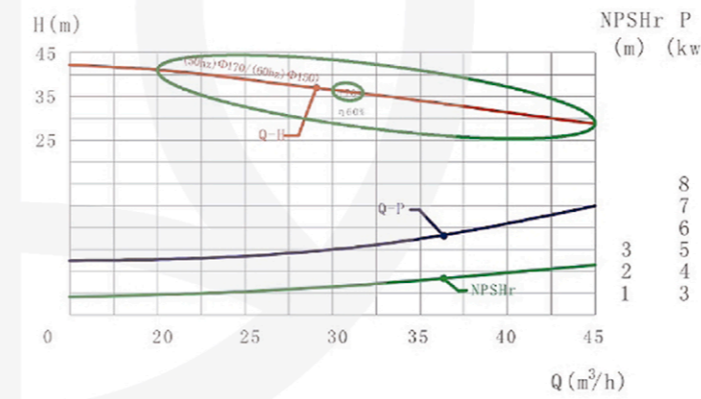
**衛生級離心泵綜合曲線圖
SCP Series pump performance curve**
SCP-10 (Q-H曲線圖/Graph)

SCP-15 (Q-H曲線圖/Graph)

SCP-20-1 (Q-H曲線圖/Graph)

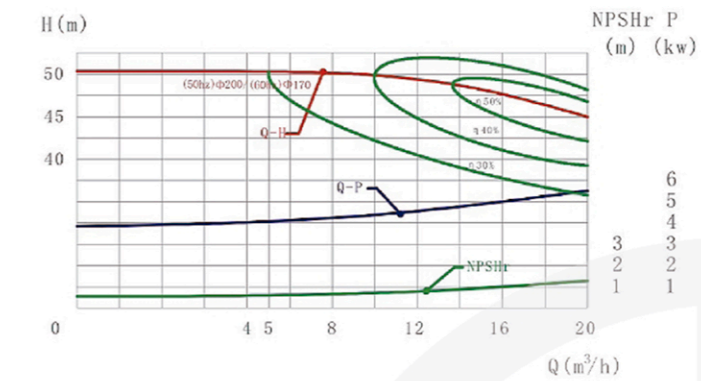
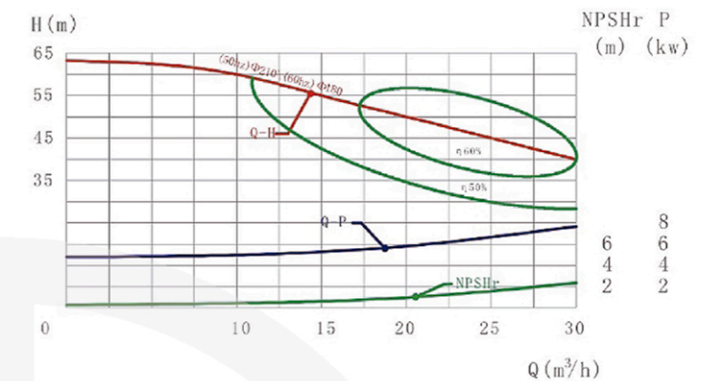
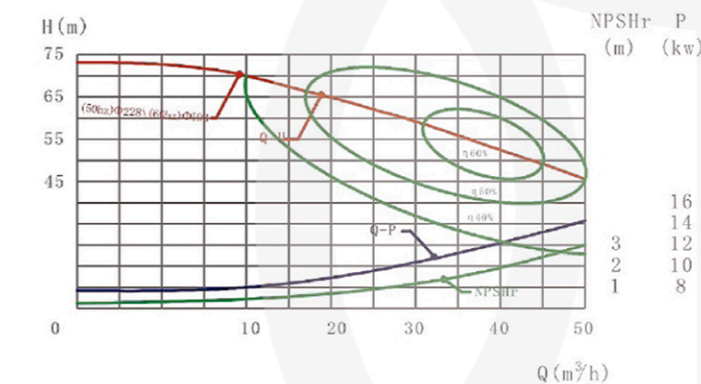
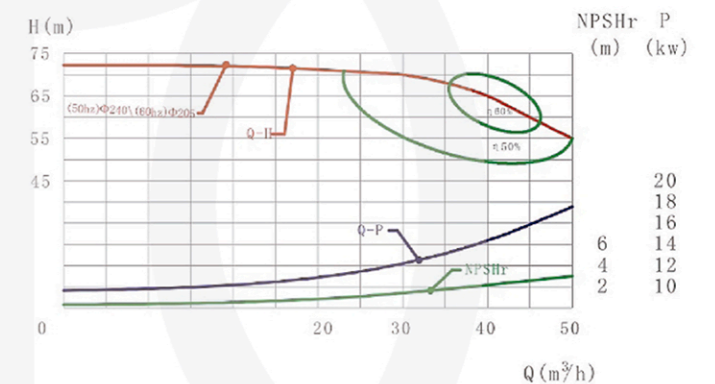
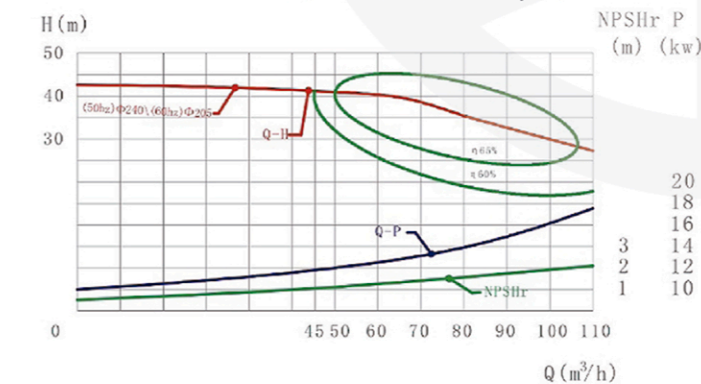
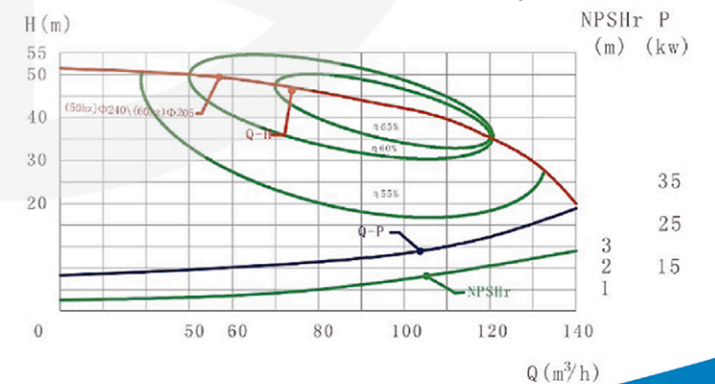
SCP-20-2 (Q-H曲線圖/Graph)

說明: 測試條件 介質清水 溫度20度C 葉輪轉速3500RPM
Note: Test condition is pure water 20°C temperature, ipmeller speed 3500RPM

※ 本公司有變更資料之權利, 訂購前請先電話確認。

SCP-25 (Q-H曲線圖/Graph)

SCP-30 (Q-H曲線圖/Graph)

SCP-35-1 (Q-H曲線圖/Graph)

SCP-35-2 (Q-H曲線圖/Graph)

SCP-40-1 (Q-H曲線圖/Graph)

SCP-40-2 (Q-H曲線圖/Graph)

說明: 測試條件 介質清水 溫度20度C 葉輪轉速3500RPM
Note: Test condition is pure water 20°C temperature, ipmeller speed 3500RPM

※ 本公司有變更資料之權利, 訂購前請先電話確認。